



## SY89850U

### Precision Low-Power LVPECL Line Driver/Receiver with Internal Termination

## General Description

The SY89850U is a 2.5V/3.3V precision, high-speed, differential receiver capable of handling clocks up to 4GHz and data streams up to 3.2Gbps.

The differential input includes Micrel's unique, 3-pin input termination architecture that allows users to interface to any differential signal (AC or DC-coupled) as small as 100mV (200mV<sub>PP</sub>) without any level shifting or termination resistor networks in the signal path. The outputs are 800mV LVPECL, with extremely fast rise/fall times guaranteed to be less than 160ps.

The SY89850U operates from a 2.5V  $\pm$ 5% supply or a 3.3V  $\pm$ 10% supply and is guaranteed over the full industrial temperature range of  $-40^{\circ}\text{C}$  to  $+85^{\circ}\text{C}$ . The SY89850U is part of Micrel's high-speed, Precision Edge<sup>®</sup> product line.

All support documentation can be found on Micrel's web site at [www.micrel.com](http://www.micrel.com).

## Typical Application

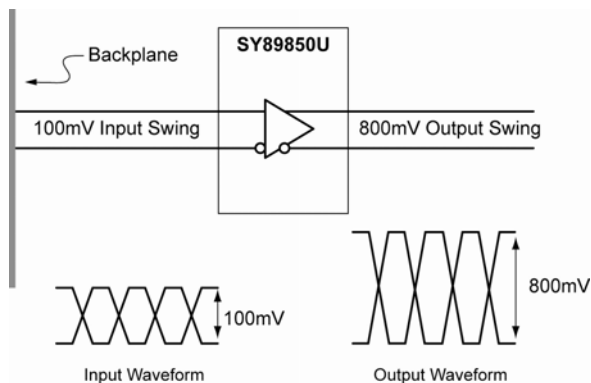

Precision Edge<sup>®</sup>

## Features

- Guaranteed AC performance over temperature and supply voltage:
  - DC- to > 3.2Gbps data rate throughput
  - 4GHz clock  $f_{\text{MAX}}$  (typ.)
  - <280ps In-to-Out  $t_{\text{pd}}$
  - <160ps  $t_r/t_f$
- Low power: 50mW (2.5V typ.)
- Ultra-low jitter design:
  - <1ps<sub>RMS</sub> random jitter
  - <10ps<sub>PP</sub> deterministic jitter
  - <10ps<sub>PP</sub> total jitter (clock)
- Unique input termination and VT pin accepts DC- and AC-coupled inputs (CML, PECL, LVDS)
- Typical 800mV (100k) LVPECL Output Swing
- Power supply 2.5V  $\pm$ 5% or 3.3V  $\pm$ 10%
- Industrial temperature range  $-40^{\circ}\text{C}$  to  $+85^{\circ}\text{C}$
- Available in ultra-small (2mm x 2mm) 8-pin MLF<sup>®</sup> package

## Applications

- Backplane buffering
- OC-12 to OC-192 SONET/SDN clock/data distribution
- All Gigabit Ethernet clock or data distribution
- Fibre Channel distribution

## Markets

- LAN/WAN
- Enterprise servers
- ATE
- Test and measurement

Precision Edge is a registered trademark of Micrel, Inc.  
MicroLeadFrame and MLF are registered trademarks of Amkor Technology.

## Ordering Information<sup>(1)</sup>

Part Number	Package Type	Operating Range	Package Marking	Lead Finish
SY89850UMG	MLF-8	Industrial	850U with Pb-Free bar-line indicator	NiPdAu Pb-Free
SY89850UMGTR <sup>(2)</sup>	MLF-8	Industrial	850U with Pb-Free bar-line indicator	NiPdAu Pb-Free

### Notes:

- Contact factory for dice availability. Dice are guaranteed at  $T_A = 25^\circ\text{C}$ , DC Electrical Only.
- Tape and Reel.

## Pin Configuration

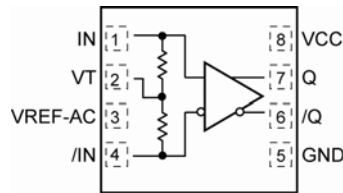

8-Pin MLF<sup>®</sup> (MLF-8)

## Pin Description

Pin Number	Pin Name	Pin Function
1, 4	IN, /IN	Differential Input: This input pair is the signal to be buffered. These inputs accept AC- or DC-coupled signals as small as 100mV. Each pin of this pair internally terminates to a VT pin through 50Ω. Note that this input will default to an indeterminate state if left open. Please refer to the "Input Interface Applications" section for more details.
2	VT	Input Termination Center-Tap: Each side of the differential input pair terminates to this pin. The VT pin provides a center-tap to a termination network for maximum interface flexibility. See "Input Interface Applications" section for more details.
3	VREF-AC	Reference Output Voltage: This output biases to $V_{CC} - 1.2\text{V}$ . Connect to VT pin when AC-coupling the input. Bypass with 0.01μF low ESR capacitor to $V_{CC}$ . Maximum sink/source current is ±1.5mA. Due to the limited drive capability, the VREF-AC pin is only intended to drive its respective VT pin. See "Input Interface Applications" section.
5	GND, Exposed Pad	Ground: Ground pin and exposed pad must be connected to the same ground plane.
7, 6	Q, /Q	Differential 100K LVPECL Output: This LVPECL output is the output of the device. Terminate through 50Ω to $V_{CC} - 2\text{V}$ . See "Output Interface Applications" section.
8	VCC	Positive Power Supply: Bypass with 0.1μF//0.01μF low ESR capacitors as close to the VCC pin as possible.

**Absolute Maximum Ratings<sup>(1)</sup>**

Supply Voltage ( $V_{CC}$ )	.....	-0.5V to +4.0V
Input Voltage ( $V_{IN}$ )	.....	-0.5V to $V_{CC}$
LVPECL Output Current ( $I_{OUT}$ )	.....	
Continuous	.....	50mA
Surge	.....	100mA
Input Current	.....	
Source or sink current on IN, /IN	.....	$\pm 50$ mA
Termination Current	.....	
Source or sink current on VT	.....	$\pm 100$ mA
Source or sink current on $V_{REF-AC}$	.....	$\pm 2$ mA
Lead Temperature (soldering, 20sec.)	.....	260°C
Storage Temperature ( $T_s$ )	.....	-65°C to +150°C

**Operating Ratings<sup>(2)</sup>**

Supply Voltage ( $V_{CC}$ )	.....	+2.375V to +2.625V
.....	.....	+3.0V to +3.6V
Ambient Temperature ( $T_A$ )	.....	-40°C to +85°C
Package Thermal Resistance <sup>(3)</sup>		
MLF <sup>®</sup> ( $\theta_{JA}$ )		
Still-Air	.....	93°C/W
MLF <sup>®</sup> ( $\psi_{JB}$ )		
Junction-to-Board	.....	60°C/W

**DC Electrical Characteristics<sup>(4)</sup>**

$T_A = -40^\circ\text{C}$  to  $+85^\circ\text{C}$ , unless noted.

Symbol	Parameter	Condition	Min	Typ	Max	Units
$V_{CC}$	Power Supply		2.375 3.0	2.5 3.3	2.625 3.6	V
$I_{CC}$	Power Supply Current	No load, max. $V_{CC}$		20	30	mA
$R_{DIFF\_IN}$	Differential Input Resistance (IN-to-/IN)		90	100	110	$\Omega$
$R_{IN}$	Input Resistance (IN-to- $V_T$ ), (/IN-to- $V_T$ )		45	50	55	$\Omega$
$V_{IH}$	Input High Voltage (IN, /IN)	Note 5	$V_{CC}-1.6$		$V_{CC}$	V
$V_{IL}$	Input Low Voltage (IN, /IN)		0		$V_{IH}-0.1$	V
$V_{IN}$	Input Voltage Swing (IN, /IN)	See Figure 1a.	0.1		1.7	V
$V_{DIFF\_IN}$	Differential Input Voltage Swing  IN-/IN	See Figure 1b.	0.2			V
$V_{T\_IN}$	In-to- $V_T$ (IN, /IN)				1.28	V
$V_{REF-AC}$	Output Reference Voltage		$V_{CC}-1.3$	$V_{CC}-1.2$	$V_{CC}-1.1$	V

**Notes:**

1. Permanent device damage may occur if Absolute Maximum Ratings are exceeded. This is a stress rating only and functional operation is not implied at conditions other than those detailed in the operational sections of this data sheet. Exposure to absolute maximum rating conditions for extended periods may affect device reliability.
2. The data sheet limits are not guaranteed if the device is operated beyond the operating ratings.
3. Package Thermal Resistance assumes exposed pad is soldered (or equivalent) to the devices most negative potential on the PCB.
4. The circuit is designed to meet the DC specifications shown in the above table after thermal equilibrium has been established.
5.  $V_{IH}$  (min) not lower than 1.2V.

## LVPECL Output DC Electrical Characteristics<sup>(6)</sup>

$V_{CC} = +2.5V \pm 5\%$  or  $+3.3V \pm 10\%$ ;  $T_A = -40^\circ C$  to  $+85^\circ C$ ;  $R_L = 50\Omega$  to  $V_{CC} - 2V$ , unless otherwise stated.

Symbol	Parameter	Condition	Min	Typ	Max	Units
$V_{CC}$	Output High Voltage Q, /Q		$V_{CC} - 1.145$		$V_{CC} - 0.895$	V
$V_{OL}$	Output Low Voltage Q, /Q		$V_{CC} - 1.945$		$V_{CC} - 1.695$	V
$V_{OUT}$	Output Voltage Swing Q, /Q	See Figure 1a.	550	800		mV
$V_{DIFF\_OUT}$	Differential Output Voltage Swing Q, /Q	See Figure 1b.	1100	1600		mV

### Note:

6. The circuit is designed to meet the DC specifications shown in the above table after thermal equilibrium has been established.

## AC Electrical Characteristics<sup>(7)</sup>

$V_{CC} = +2.5V \pm 5\%$  or  $+3.3V \pm 10\%$ ;  $T_A = -40^\circ C$  to  $+85^\circ C$ ;  $R_L = 50\Omega$  to  $V_{CC} - 2V$ , unless otherwise stated.

Symbol	Parameter	Condition	Min	Typ	Max	Units
$f_{MAX}$	Maximum Operating Frequency	NRZ Data	3.2			Gbps
		$V_{OUT} \geq 400mV$ Clock		4		GHz
$t_{pd}$	Propagation Delay IN-to-Q	$V_{IN} \geq 100mV$	180	260	360	ps
$t_{pd}$ Tempco	Differential Propagation Delay Temperature Coefficient			115		fs/ $^\circ C$
$t_{JITTER}$	Data Random Jitter (RJ) Deterministic Jitter (DJ)	Note 8			1	ps <sub>RMS</sub>
		Note 9			10	ps <sub>PP</sub>
	Clock Cycle-to-Cycle Jitter Total Jitter (TJ)	Note 10			1	ps <sub>RMS</sub>
		Note 11			10	ps <sub>PP</sub>
$t_r, t_f$	Rise/Fall Time (20% to 80%) Q, /Q	At full output swing.	50	100	160	ps

### Notes:

- The circuit is designed to meet the AC specifications shown in the above table after thermal equilibrium has been established.
- Random jitter is measured with a K28.7 comma detect character pattern, measured at 2.5Gbps and 3.2Gbps.
- Deterministic jitter is measured at 2.5Gbps and 3.2Gbps, with both K28.5 and  $2^{23}-1$  PRBS pattern.
- Cycle-to-cycle jitter definition: the variation of periods between adjacent cycles,  $T_n - T_{n-1}$  where T is the time between rising edges of the output signal.
- Total jitter definition: with an ideal clock input of frequency  $< f_{MAX}$ , no more than one output edge in  $10^{12}$  output edges will deviate by more than the specified peak-to-peak jitter value.

### Single-Ended and Differential Swings

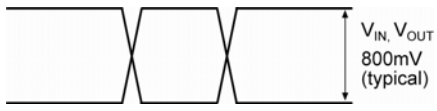

Figure 1a. Singled-Ended Voltage Swing

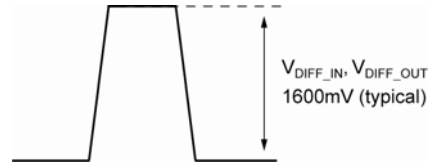
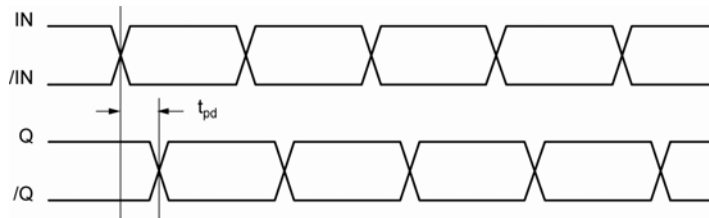

Figure 1b. Differential Voltage Swing

### Timing Diagram



### Typical Operating Characteristics

$V_{CC} = 3.3V$ ,  $GND = 0V$ ,  $V_{IN} = \geq 400mV_{pp}$ ,  $t_r/t_f \leq 300ps$ ,  $T_A = 25^\circ C$ , unless otherwise stated.

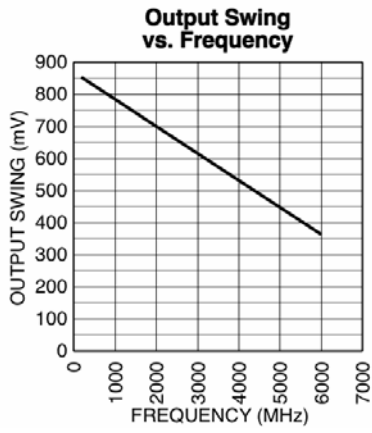

### Functional Characteristics

$V_{CC} = 3.3V$ ,  $GND = 0V$ ,  $V_{IN} = \geq 400mV_{pp}$ ,  $t_r/t_f \leq 300ps$ ,  $T_A = 25^\circ C$ , unless otherwise stated.

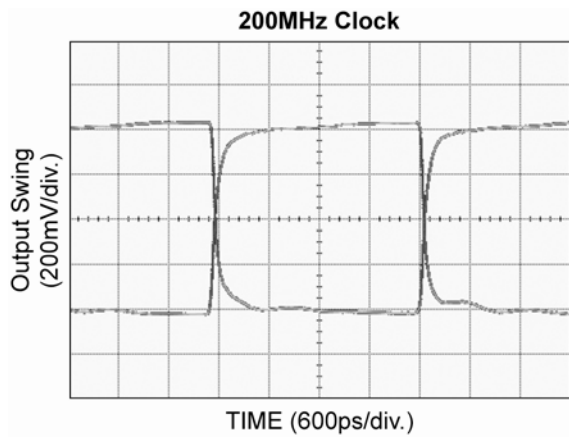
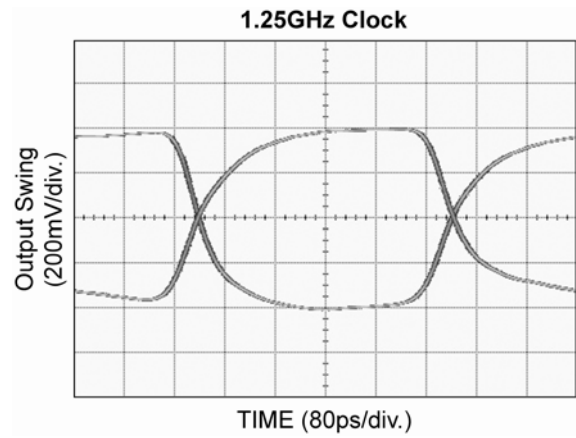
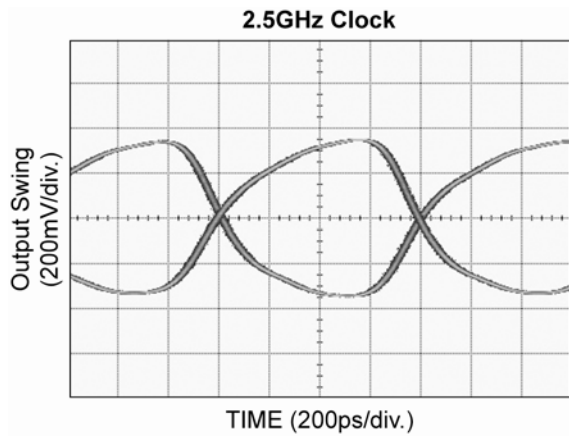
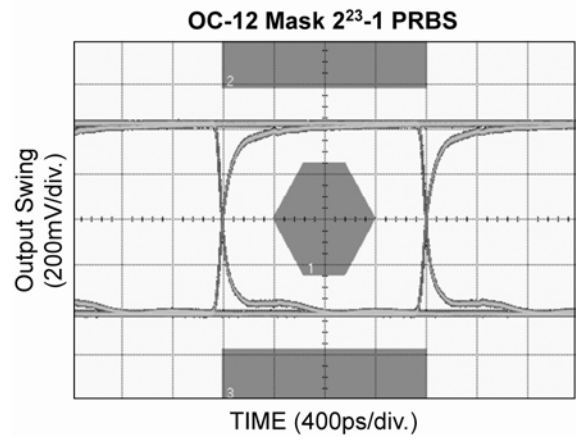
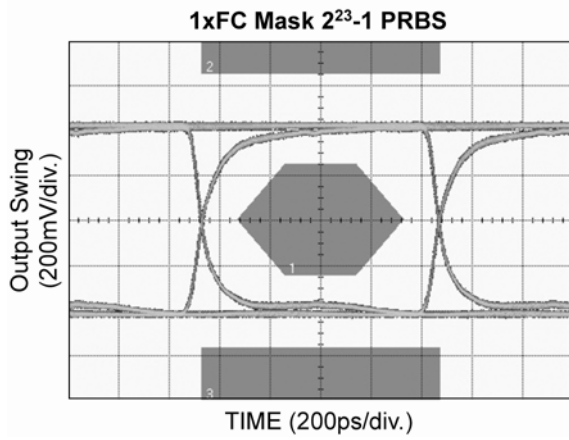

### Input and Output Stages

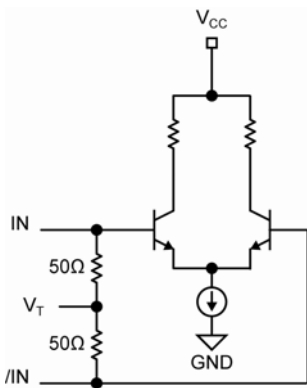

Figure 2a. Simplified Differential Input Stage

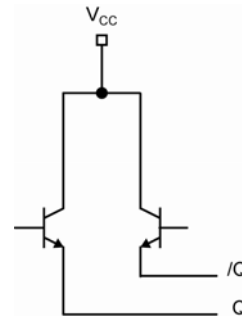

Figure 2b. Simplified LVPECL Output Stage

### Input Interface Applications

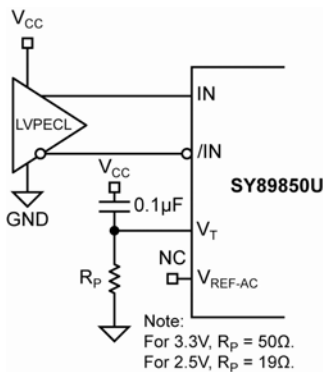

Figure 3a. LVPECL Interface (DC-Coupled)

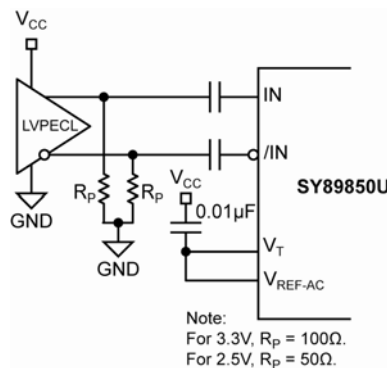
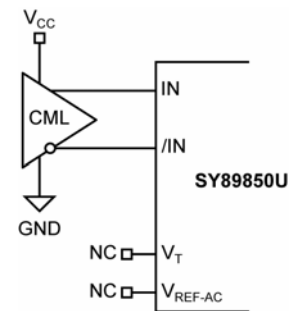

Figure 3b. LVPECL Interface (AC-Coupled)



Option: may connect V<sub>T</sub> to V<sub>CC</sub>

Figure 3c. CML Interface (DC-Coupled)

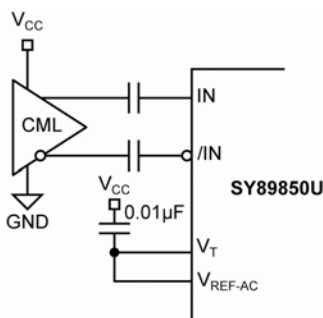

Figure 3d. CML Interface (AC-Coupled)

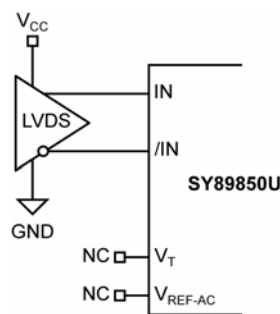

Figure 3e. LVDS Interface (DC-Coupled)



## Output Interface Applications

LVPECL has a high input impedance, a very low output impedance (open emitter), and a small signal swing which results in low EMI. LVPECL is ideal for driving 50Ω- and 100Ω-controlled impedance transmission lines. There are several techniques for

terminating the LVPECL output: Parallel Termination-Thevenin Equivalent, Parallel Termination (3-resistor), and AC-coupled Termination. Unused output pairs may be left floating. However, single-ended outputs must be terminated, or balanced.

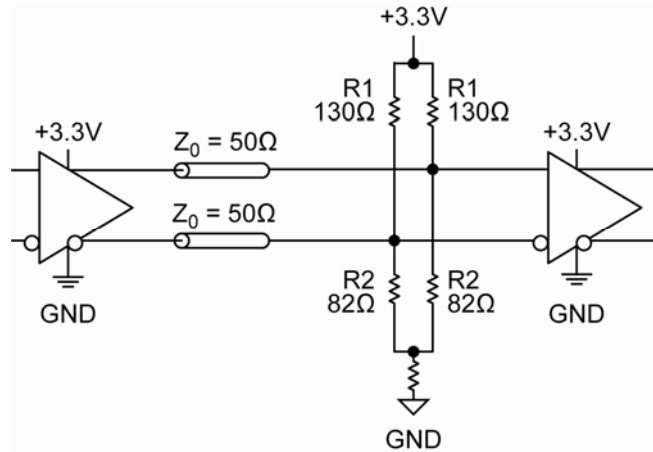

**Note:**

1. For +2.5V systems, R1 = 250Ω, R2 = 62.5Ω.

**Figure 4a. Parallel Termination-Thevenin Equivalent**

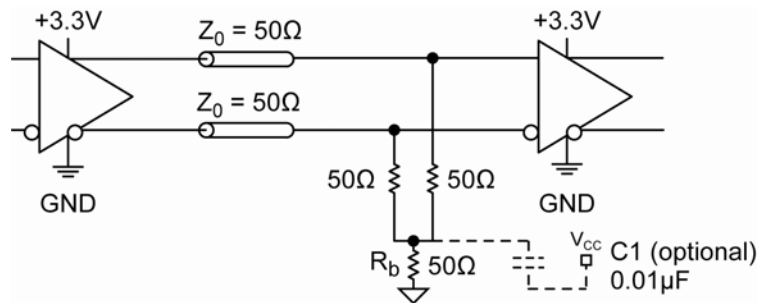

**Notes:**

1. Power-saving alternative to Thevenin termination.
2. Place termination resistors as close to destination inputs as possible.
3. R<sub>b</sub> resistor sets the DC bias voltage, equal to V<sub>T</sub>.
4. For 2.5V systems, R<sub>b</sub> = 19Ω.

**Figure 4b. Parallel Termination (3-Resistor)**

## Related Product and Support Documentation

Part Number	Function	Data Sheet Link
SY58601U	Ultra-Precision Differential 800mV LVPECL Line Driver/Receiver with Internal Termination	<a href="http://www.micrel.com/product-info/products/sy58601u.shtml">www.micrel.com/product-info/products/sy58601u.shtml</a>
	MLF <sup>®</sup> Application Note	<a href="http://www.amkor.com/products/notes_papers/MLF_AppNote.pdf">www.amkor.com/products/notes_papers/MLF_AppNote.pdf</a>
HBW Solutions	New Products and Applications	<a href="http://www.micrel.com/product-info/products/solutions.shtml">www.micrel.com/product-info/products/solutions.shtml</a>

**Package Information**

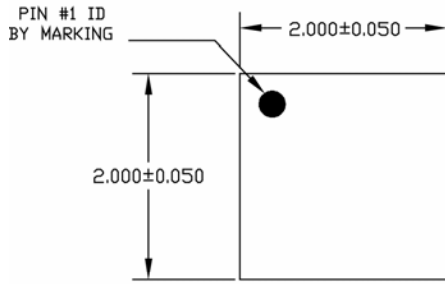

TOP VIEW

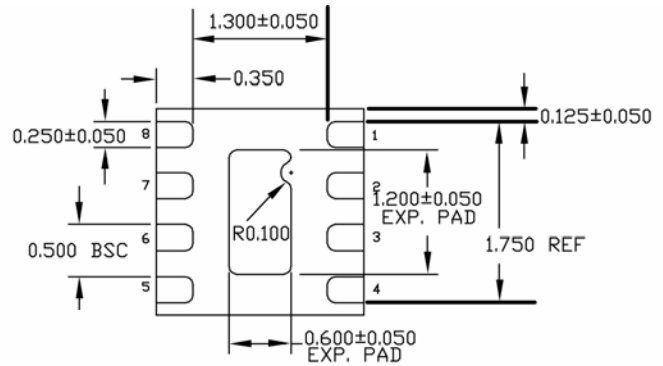

BOTTOM VIEW

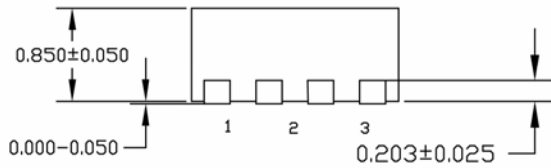

SIDE VIEW

- NOTE:
1. ALL DIMENSIONS ARE IN MILLIMETERS.
  2. MAX. PACKAGE WARPAGE IS 0.05 mm.
  3. MAXIMUM ALLOWABLE BURRS IS 0.076 mm IN ALL DIRECTIONS.
  4. PIN #1 ID ON TOP WILL BE LASER/INK MARKED.

**8-Pin Ultra-Small EPAD MLF<sup>®</sup> (MLF-8)**

**MICREL, INC. 2180 FORTUNE DRIVE SAN JOSE, CA 95131 USA**  
 TEL +1 (408) 944-0800 FAX +1 (408) 474-1000 WEB <http://www.micrel.com>

The information furnished by Micrel in this data sheet is believed to be accurate and reliable. However, no responsibility is assumed by Micrel for its use. Micrel reserves the right to change circuitry and specifications at any time without notification to the customer.

Micrel Products are not designed or authorized for use as components in life support appliances, devices or systems where malfunction of a product can reasonably be expected to result in personal injury. Life support devices or systems are devices or systems that (a) are intended for surgical implant into the body or (b) support or sustain life, and whose failure to perform can be reasonably expected to result in a significant injury to the user. A Purchaser's use or sale of Micrel Products for use in life support appliances, devices or systems is a Purchaser's own risk and Purchaser agrees to fully indemnify Micrel for any damages resulting from such use or sale.

© 2005 Micrel, Incorporated.